

M2p.59xx-x4 - 16 bit general purpose Digitizer

- Up to 125 MS/s on four or 80 MS/s on eight channels
- Ultra Fast PCI Express x4 interface
- Simultaneously sampling on all channels
- Separate dedicated 16 bit ADC and amplifier per channel
- 6 input ranges: ± 200 mV up to ± 10 V
- 512 MSamples (1 GByte) on-board memory
- Window, re-arm, OR/AND trigger
- Synchronization of up to 16 cards per system
- Features: Single-Shot, Streaming, Multiple Recording, Gated Sampling, ABA, Timestamps
- Direct data transfer to CUDA GPU using SCAPP option

Speed	SNR	ENOB
20 MS/s		
40 MS/s		
80 MS/s		
125 MS/s		

M2p
series

- PCIe x4 Gen 1 Interface
- Works with x4/x8/x16 PCIe slots
- Sustained streaming mode more than 600 MB/s
- Half-length PCIe Form Factor

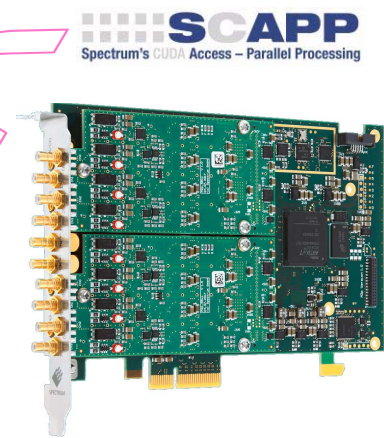

Operating Systems	Recommended Software	Drivers
<ul style="list-style-type: none"> • Windows 7, 8, 10 • Linux Kernel 2.6, 3.x, 4.x • Windows/Linux 32 and 64 bit 	<ul style="list-style-type: none"> • Visual Basic, Visual C++, Borland C++, GNU C++, Borland Delphi, VB.NET, C#, J#, Java, Python • SBench 6 	<ul style="list-style-type: none"> • MATLAB • LabVIEW • LabWindows/CVI • IVI

Model	single-ended channels:				differential channels (non-isolated)		
	1 ch	2 ch	4 ch	8 ch	1 ch	2 ch	4 ch
M2p.5920-x4	20 MS/s (OEM version)				20 MS/s (OEM version)		
M2p.5921-x4	20 MS/s	20 MS/s			20 MS/s	20 MS/s	
M2p.5922-x4	20 MS/s	20 MS/s	20 MS/s		20 MS/s	20 MS/s	
M2p.5926-x4	20 MS/s	20 MS/s	20 MS/s		20 MS/s	20 MS/s	20 MS/s
M2p.5923-x4	20 MS/s	20 MS/s	20 MS/s	20 MS/s	20 MS/s	20 MS/s	20 MS/s
M2p.5930-x4	40 MS/s (OEM version)				40 MS/s (OEM version)		
M2p.5931-x4	40 MS/s	40 MS/s			40 MS/s	40 MS/s	
M2p.5932-x4	40 MS/s	40 MS/s	40 MS/s		40 MS/s	40 MS/s	
M2p.5936-x4	40 MS/s	40 MS/s	40 MS/s		40 MS/s	40 MS/s	40 MS/s
M2p.5933-x4	40 MS/s	40 MS/s	40 MS/s	40 MS/s	40 MS/s	40 MS/s	40 MS/s
M2p.5940-x4	80 MS/s				80 MS/s		
M2p.5941-x4	80 MS/s	80 MS/s			80 MS/s	80 MS/s	
M2p.5942-x4	80 MS/s	80 MS/s	80 MS/s		80 MS/s	80 MS/s	
M2p.5946-x4	80 MS/s	80 MS/s	80 MS/s		80 MS/s	80 MS/s	80 MS/s
M2p.5943-x4	80 MS/s	80 MS/s	80 MS/s	80 MS/s	80 MS/s	80 MS/s	80 MS/s
M2p.5960-x4	125 MS/s				125 MS/s		
M2p.5961-x4	125 MS/s	125 MS/s			125 MS/s	125 MS/s	
M2p.5962-x4	125 MS/s	125 MS/s	80 MS/s		125 MS/s	125 MS/s	
M2p.5966-x4	125 MS/s	125 MS/s	125 MS/s		125 MS/s	125 MS/s	125 MS/s
M2p.5968-x4	125 MS/s	125 MS/s	125 MS/s	80 MS/s	125 MS/s	125 MS/s	125 MS/s

General Information

The M2p.59xx series allows recording of up to eight Single-Ended channels or up to four differential channels both with sampling rates of up to 125 MS/s. These PCI Express cards offer outstanding A/D features both in resolution and speed. The cards can be switched between Single-Ended inputs with a programmable offset and true differential inputs. If used in differential mode each two inputs are connected together reducing the number of available channels by half. Importantly, the high-resolution 16-bit ADCs deliver sixteen times more resolution than digitizers using older 12-bit technology and 256 times more resolution than what is available from digital scopes that commonly use 8-bit ADCs. All boards of the M2p.59xx series may use the whole installed on-board memory of up to 512 MSamples, completely for the currently activated number of channels.

Software Support

Windows drivers

The cards are delivered with drivers for Windows 7, Windows 8 and Windows 10 (each 32 bit and 64 bit). Programming examples for Visual C++, Borland C++ Builder, LabWindows/CVI, Borland Delphi, Visual Basic, VB.NET, C#, J#, Python, Java and IVI are included.

Linux Drivers



All cards are delivered with full Linux support. Pre-compiled kernel modules are included for the most common distributions like RedHat, Fedora, Suse, Ubuntu LTS or Debian. The Linux support includes SMP systems, 32 bit and 64 bit systems, versatile programming examples for Gnu C++, Python as well as the possibility to get the driver sources for your own compilation.

SBench 6

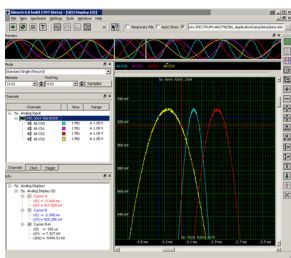

A base license of SBench 6, the easy-to-use graphical operating software for Spectrum cards, is included in the delivery. The base license makes it possible to test the card, display acquired data and make some basic measurements. It's a valuable tool for checking the card's performance and assisting with the unit's initial

setup. The cards also come with a demo license for the SBench 6 professional version. This license gives the user the opportunity to test the additional features of the professional version with their hardware. The professional version contains several advanced measurement functions, such as FFTs and X/Y display, import and export utilities as well as support for all acquisition modes including data streaming. Data streaming allows the cards to continuously acquire data and transfer it directly to the PC RAM or hard disk. SBench 6 has been optimized to handle data files of several GBytes. SBench 6 runs under Windows as well as Linux (KDE, GNOME and Unity) operating systems. A test version of SBench 6 can be downloaded directly over the internet and can run the professional version in a simulation mode without any hardware installed. Existing customers can also request a demo license for the professional version from Spectrum. More details on SBench 6 can be found in the SBench 6 data sheet.

Third-party products

Spectrum supports the most popular third-party software products such as LabVIEW, MATLAB or LabWindows/CVI. All drivers come with detailed documentation and working examples are included in the delivery. Support for other software packages, like VEE or DasyLab, can also be provided on request.

SCAPP – CUDA GPU based data processing

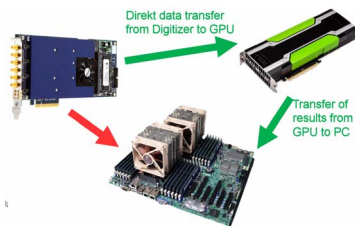

For applications requiring high powered signal and data processing Spectrum offers SCAPP (Spectrum CUDA Access for Parallel Processing). The SCAPP SDK allows a direct link between Spectrum digitizers and CUDA based GPU cards. Once in the

GPU users can harness the processing power of the GPU's multiple (up to 5000) processing cores and large (up to 24 GB) memories. SCAPP uses an RDMA process to send data at the digitizers full PCIe transfer speed to the GPU card. The SDK includes a set of examples for interaction between the digitizer and the GPU card and another set of CUDA parallel processing examples with easy build-

ing blocks for basic functions like filtering, averaging, data de-multiplexing, data conversion or FFT. All the software is based on C/ C++ and can easily be implemented, expanded and modified with normal programming skills.

Hardware features and options

PCI Express x4

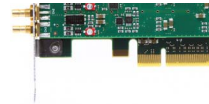

The M2p series cards use a PCI Express x4 Gen 1 connection. They can be used in PCI Express x4, x8 and x16 slots with hosts supporting Gen 1, Gen 2 or Gen 3.

The maximum sustained data transfer rate is more than 600 MByte/s (read direction) or TBD MByte/s (write direction) per slot. Physically supported slots that are electrically connected with only x1 or x2 can also be used with the M2p series cards, but with reduced data transfer rates.

Connections

The cards are equipped with SMB connectors for the analog signals as well as for the external trigger and clock input. In addition, there are four MMCX connectors: one multi-function output (X0) and three multi-function I/O connectors (X1, X2, X3). These multi-function connectors can be individually programmed to perform different functions:



- Clock output (X0 only)
- Trigger output
- Status output (armed, triggered, ready, ...)
- Synchronous digital inputs, being stored inside the analog data samples
- Asynchronous I/O lines

Input Amplifier

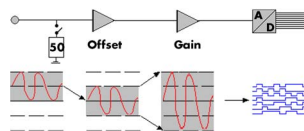

The analog inputs can be adapted to real world signals using a wide variety of settings that are individual for each channel. By using software commands the input termination can be changed

between 50 Ohm and 1 MOhm, one can select a matching input range and the signal offset can be compensated for.

Differential inputs

With a simple software command the inputs can individually be switched from single-ended (in relation to ground) to differential by combining each two single-ended inputs to one differential input. When the inputs are used in differential mode the A/D converter measures the difference between two lines with relation to system ground.

Automatic on-board calibration

All of the channels are calibrated in factory before the board is shipped. To compensate for different variations like PC power supply, temperature and aging, the software driver provides routines for an automatic onboard offset and gain calibration of all input ranges. All the cards contain a high precision on-board calibration reference.

Digital inputs

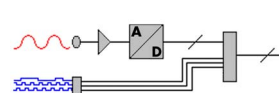

This option acquires additional synchronous digital channels phase-stable with the analog data. As default a maximum of 3 additional digital inputs are available on the front plate of the card using the multi-purpose I/O lines.

Ring buffer mode

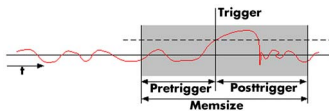

The ring buffer mode is the standard mode of all oscilloscope instruments. Digitized data is continuously written into a ring memory until a trigger event is detected. After the trigger, post-trigger samples are recorded and pre-trigger samples can also be stored. The number of pre-trigger samples available simply equals the total ring memory size minus the number of post trigger samples.

FIFO mode

The FIFO or streaming mode is designed for continuous data transfer between the digitizer card and the PC memory. When mounted in a PCI Express x4 Gen 1 interface read streaming speeds of up to 600 MByte/s are possible. The control of the data stream is done automatically by the driver on interrupt request basis. The complete installed onboard memory is used to buffer the data, making the continuous streaming process extremely reliable.

Channel trigger

The digitizers offer a wide variety of trigger modes. These include a standard triggering mode based on a signals level and slope, like that found in most oscilloscopes. It is also possible to define a window mode, with two trigger levels, that enables triggering when signals enter or exit the window. Each input has its own trigger circuit which can be used to setup conditional triggers based on logical AND/OR patterns. All trigger modes can be combined with a re-arming mode for accurate trigger recognition even on noisy signals.

External trigger input

All boards can be triggered using an external analog or digital signal. The external trigger input has one comparator that can be used for standard edge and level triggers.

Multiple Recording

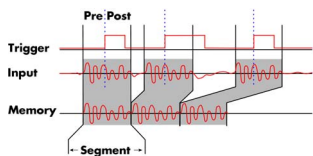

The Multiple Recording mode allows the recording of several trigger events with an extremely short re-arming time. The hardware doesn't need to be restarted in between. The on-board memory is divided in several segments of the same size. Each of them is filled with data if a trigger event occurs. Pre- and posttrigger of the segments can be programmed. The number of acquired segments is only limited by the used memory and is unlimited when using FIFO mode.

Gated Sampling

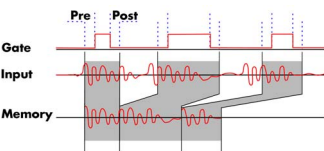

The Gated Sampling mode allows data recording controlled by an external gate signal. Data is only recorded if the gate signal has a programmed level. In addition a pre-area before start of the gate signal as well as a post area after end of the gate signal can be acquired. The number of gate segments is only limited by the used memory and is unlimited when using FIFO mode.

ABA mode

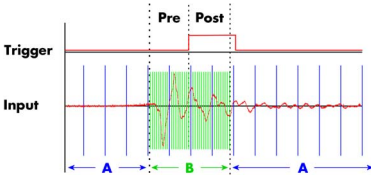

The ABA mode combines slow continuous data recording with fast acquisition on trigger events. The ABA mode works like a slow data logger combined with a

fast digitizer. The exact position of the trigger events is stored as timestamps in an extra memory.

Timestamp

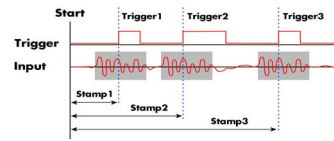

The timestamp function writes the time positions of the trigger events in an extra memory. The timestamps are relative to the start of recording, a defined zero time, externally synchronized to a radio clock, an IRIG-B or a GPS receiver.

Using the external synchronization gives a precise time relation for acquisitions of systems on different locations.

External clock input and output

Using a dedicated connector a sampling clock can be fed in from an external system. Additionally it's also possible to output the internally used sampling clock on a separate connector to synchronize external equipment to this clock.

Reference clock

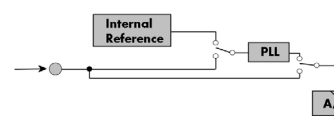

The option to use a precise external reference clock (typically 10 MHz) is necessary to synchronize the instrument for high-quality measurements with external equipment (like a signal source). It's also possible to enhance the stability of the sampling clock in this way. The driver automatically generates the requested sampling clock from the fed in reference clock.

Star-Hub

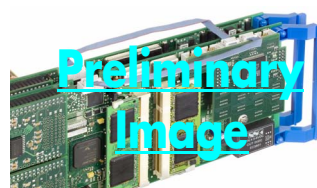

The Star-Hub is an additional module allowing the phase stable synchronisation of up to 16 boards in one system. Independent of the number of boards there is no phase delay between all channels. The Star-Hub distributes trigger and clock information between all boards. As a result all connected boards are running with the same clock and the same trigger. All trigger sources can be combined with OR/AND allowing all channels of all cards to be trigger source at the same time.

External Amplifiers



For the acquisition of extremely small voltage levels with a high bandwidth a series of external amplifiers is available. Each of the one channel amplifiers is working with a fixed input impedance and allows - depending on the bandwidth - to select different amplification levels between x10 (20 dB) up to x1000 (60 dB). Using the external amplifiers of the SPA series voltage levels in the μV and mV area can be acquired.

Technical Data

Analog Inputs

Resolution		16 bit (can be reduced to acquire simultaneous digital inputs)
Input Range	software programmable	± 200 mV, ± 500 mV, ± 1 V, ± 2 V, ± 5 V, ± 10 V
Input Type	software programmable	Single-ended or True Differential
Input Offset (single-ended)	software programmable	programmable to $\pm 100\%$ of input range in steps of 1%
ADC Differential non linearity (DNL)	ADC only	592x: \pm TBD/TBD LSB (typ./max.) 593x: $\pm 0.5/\pm 0.9$ LSB (typ./max.) 594x: $\pm 0.5/\pm 0.9$ LSB (typ./max.) 596x: $\pm 0.5/\pm 0.9$ LSB (typ./max.)
ADC Integral non linearity (INL)	ADC only	592x: \pm TBD/TBD LSB (typ./max.) 593x: $\pm 1.5/\pm 7.5$ LSB (typ./max.) 594x: $\pm 1.5/\pm 7.5$ LSB (typ./max.) 596x: $\pm 1.5/\pm 7.5$ LSB (typ./max.)
Offset error (full speed)	after warm-up and calibration	$\leq 0.1\%$
Gain error (full speed)	after warm-up and calibration	$\leq 0.1\%$
Crosstalk: Signal ≤ 1 MHz, 50 ohm	range $\leq \pm 1$ V	\leq TBD dB on adjacent channels
Crosstalk: Signal ≤ 1 MHz, 50 ohm	range $\geq \pm 2$ V	\leq TBD dB on adjacent channels
Analog Input impedance	software programmable	50 Ω / 1 M Ω TBD pF
Analog input coupling	fixed	DC
Over voltage protection	range $\leq \pm 1$ V	± 5 V
Over voltage protection	range $\geq \pm 2$ V	± 50 V
CMRR (Common Mode Rejection Ratio)	range $\leq \pm 1$ V	100 kHz: TBD dB, 1 MHz: TBD dB, 10 MHz: TBD dB
CMRR (Common Mode Rejection Ratio)	range $\geq \pm 2$ V	100 kHz: TBD dB, 1 MHz: TBD dB, 10 MHz: TBD dB
Channel selection (single-ended inputs)	software programmable	1, 2, 4 or 8 channels (maximum is model dependent)
Channel selection (true differential inputs)	software programmable	1, 2 or 4 channels (maximum is model dependent)

Trigger

Available trigger modes	software programmable	Channel Trigger, External, Software, Window, Pulse, Re-Arm, Spike, Or/And, Delay
Trigger level resolution	software programmable	16 bit
Trigger edge	software programmable	Rising edge, falling edge or both edges
Trigger pulse width	software programmable	0 to [4G - 1] samples in steps of 1 sample
Trigger delay	software programmable	0 to [4G - 1] samples in steps of 1 sample
Multi, Gate: re-arming time		< TBD samples (+ programmed pretrigger)
Pretrigger at Multi, ABA, Gate, FIFO	software programmable	8 up to [32 kSamples / number of active channels] in steps of 8
Posttrigger	software programmable	8 up to [8G - 4] samples in steps of 8 (defining pretrigger in standard scope mode)
Memory depth	software programmable	8 up to [installed memory / number of active channels] samples in steps of 8
Multiple Recording/ABA segment size	software programmable	8 up to [installed memory / number of active channels] samples in steps of 8
Trigger output delay		TBD
Internal/External trigger accuracy		1 sample
External trigger		Ext
External trigger type		Single level comparator
External trigger impedance	software programmable	50 Ω / 5 k Ω
External trigger input level		± 5 V (5 k Ω), ± 2.5 V (50 Ω), \pm TBD
External trigger maximum voltage		TBD
External trigger sensitivity (minimum required signal swing)		
External trigger level	software programmable	± 5 V in steps of TBD mV
External trigger bandwidth DC	50 Ω 5 k Ω	DC to TBD MHz DC to TBD MHz
Minimum external trigger pulse width		≥ 2 samples
		X1, X2, X3 3.3V LVTTTL logic inputs For electrical specifications refer to „Multi Purpose I/O lines“ section.

Clock

Clock Modes	software programmable	internal PLL, external clock, external reference clock, sync
Internal clock range (PLL mode)	software programmable	1 kS/s to max using internal reference, TBD to max using external reference clock
Internal clock accuracy		≤ 1.5 ppm
Internal clock setup granularity		TBD
External reference clock range	software programmable	TBD
External reference clock impedance	software programmable	50 Ω / 5 k Ω
External reference clock range		see „Dynamic Parameters“ table below
External reference clock delay to internal clock		TBD ns
External clock type		Single level comparator
External clock impedance	software programmable	50 Ω / 5 k Ω
External clock input level		± 5 V (5 k Ω), ± 2.5 V (50 Ω), \pm TBD
External clock maximum voltage		TBD
External clock sensitivity (minimum required signal swing)		
External clock level	software programmable	± 5 V in steps of TBD mV
External clock edge		rising edge used
External reference clock input duty cycle		45% - 55%
Clock output electrical specification		Available via Multi Purpose output X0. Refer to „Multi Purpose I/O lines“ section.
Synchronization clock divider	software programmable	TBD
ABA mode clock divider for slow clock	software programmable	TBD in steps of 8

Multi Purpose I/O lines (front-plate)

Number of multi purpose output lines		one, named X0	
Number of multi purpose input/output lines		three, named X1, X2, X3	
Multi Purpose line		X0	X1, X2, X3
Input: available signal types	software programmable	n.a.	Asynchronous Digital-In, Synchronous Digital-In, Timestamp Reference Clock, Logic trigger
Input: impedance		n.a.	10 k Ω to 3.3 V
Input: maximum voltage level		n.a.	-0.5 V to +4.0 V
Input: signal levels		n.a.	3.3 V LVTTTL
Output: available signal types	software programmable	Run-, Arm-, Trigger-Output, Asynchronous Digital-Out, ADC Clock Output,	Run-, Arm-, Trigger-Output, Asynchronous Digital-Out
Output: impedance		50 Ω	
Output: drive strength		Capable of driving 50 Ω loads, maximum drive strength \pm 48 mA	
Output: type / signal levels		3.3V LVTTTL, TTL compatible for high impedance loads	
Output: update rate		sampling clock	

Connectors

Analog Inputs		SMB female (one for each single-ended input)	Cable-Type: Cab-3f-xx-xx
Trigger Input		SMB female	Cable-Type: Cab-3f-xx-xx
Clock Input		SMB female	Cable-Type: Cab-3f-xx-xx
Multi Purpose I/O		MMCX female (4 lines)	Cable-Type: Cab-1m-xx-xx

Environmental and Physical Details

Dimension (Single Card)		168 mm ($\frac{1}{2}$ PCIe length) x 107 mm x 20 mm (single slot width)
Dimension (Card with option SH16tm installed)		168 mm ($\frac{1}{2}$ PCIe length) x 107 mm x 40 mm (double slot width)
Dimension (Card with option SH16ex installed)		241 mm ($\frac{3}{4}$ PCIe length) x 107 mm x 20 mm (single slot width)
Weight (M2p.59xx series)	maximum	TBD g
Weight (Star-Hub Option -sh16ex, -sh16tm)	including 16 sync cables	TBD g
Warm up time		10 minutes
Operating temperature		0°C to 50°C
Storage temperature		-10°C to 70°C
Humidity		10% to 90%

PCI Express specific details

PCIe slot type		x4 Generation 1
PCIe slot compatibility (physical)		x4, x8, x16
PCIe slot compatibility (electrical)		x1, x4, x8, x16, Generation 1, Generation 2, Generation 3
Sustained streaming mode		> 600 MB/s (measured with a chipset supporting a TLP size of 256 bytes, using PCIe x4 Gen1)

Certification, Compliance, Warranty

EMC Immunity		Compliant with CE Mark
EMC Emission		Compliant with CE Mark
Product warranty		5 years starting with the day of delivery
Software and firmware updates		Life-time, free of charge

Power Consumption

	3.3V	12V	Total
M2p.59x0, 59x1, 59x2	TBD A	TBD A	TBD W
M2p.59x3, 59x6	TBD A	TBD A	TBD W

MTBF

MTBF		TBD hours
------	--	-----------

Dynamic Parameters

	M2i.492x	M2i.493x	M2i.494x	M2i.496x
max internal/external clock	20 MS/s	40 MS/s	80 MS/s	125 MS/s
min internal clock	1 kS/s	1 kS/s	1 kS/s	1 kS/s
min external reference clock	TBD MS/s	TBD MS/s	TBD MS/s	TBD MS/s
-3 dB bandwidth	> 10 MHz	> 20 MHz	> 40 MHz	> 50 MHz
Zero noise level (Range ± 200 mV and ± 2 V)	< TBD LSB rms	< TBD LSB rms	< TBD LSB rms	< TBD LSB rms
Zero noise level (all other ranges)	< TBD LSB rms	< TBD LSB rms	< TBD LSB rms	< TBD LSB rms
Test - sampling rate	20 MS/s	40 MS/s	80 MS/s	125 MS/s
Test signal frequency	1 MHz	1 MHz	1 MHz	1 MHz
SNR (typ)	\geq TBD dB	\geq TBD dB	\geq TBD dB	\geq TBD dB
THD (typ)	\leq TBD dB	\leq TBD dB	\leq TBD dB	\leq TBD dB
SFDR (typ), excl. harm.	\geq TBD dB	\geq TBD dB	\geq TBD dB	\geq TBD dB
ENOB (based on SNR)	\geq TBD LSB	\geq TBD LSB	\geq TBD LSB	\geq TBD LSB
ENOB (based on SINAD)	\geq TBD LSB	\geq TBD LSB	\geq TBD LSB	\geq TBD LSB

Dynamic parameters are measured at ± 1 V input range (if no other range is stated) and 50 Ohm termination with the samplerate specified in the table. Measured parameters are averaged 20 times to get typical values. Test signal is a pure sine wave of the specified frequency with > 99% amplitude. SNR and RMS noise parameters may differ depending on the quality of the used PC. SNR = Signal to Noise Ratio, THD = Total Harmonic Distortion, SFDR = Spurious Free Dynamic Range, SINAD = Signal Noise and Distortion, ENOB = Effective Number of Bits. For a detailed description please see application note 002.

Hardware block diagram

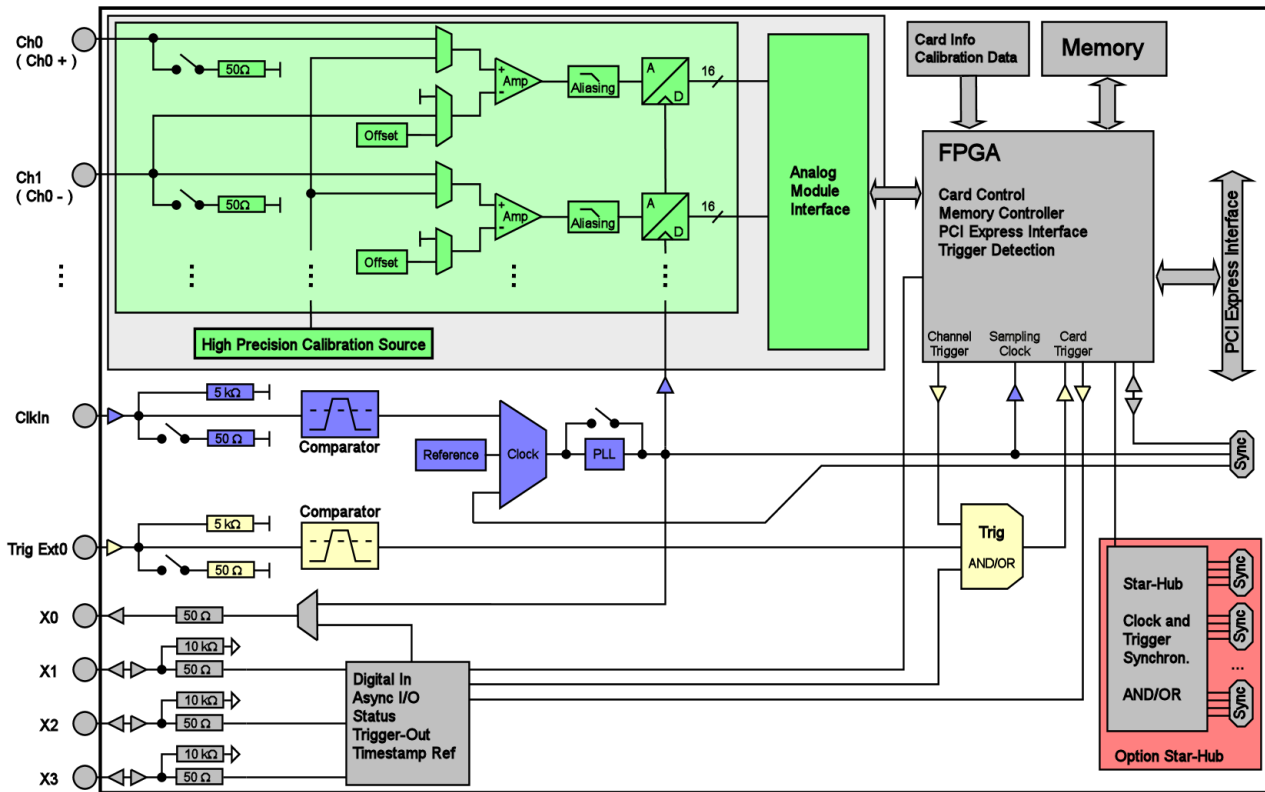

Order Information

The card is delivered with 512 MSample on-board memory and supports standard acquisition (Scope), FIFO acquisition (streaming), Multiple Recording, Gated Sampling, ABA mode and Timestamps. Operating system drivers for Windows/Linux 32 bit and 64 bit, examples for C/C++, LabVIEW (Windows), MATLAB (Windows and Linux), LabWindows/CVI, IVI, .NET, Delphi, Visual Basic, Java, Python and a Base license of the oscilloscope software SBench 6 are included.

Adapter cables are not included. Please order separately!

PCI Express x8

Order no.	A/D Resolution	Standard mem	Single-Ended Inputs		Differential Inputs		
M2p.5920-x4	16 Bit	512 MSample	1 channel	20 MS/s	1 channel	20 MS/s	OEM only
M2p.5921-x4	16 Bit	512 MSample	2 channels	20 MS/s	2 channels	20 MS/s	
M2p.5922-x4	16 Bit	512 MSample	4 channels	20 MS/s	2 channels	20 MS/s	
M2p.5926-x4	16 Bit	512 MSample	4 channels	20 MS/s	4 channels	20 MS/s	
M2p.5923-x4	16 Bit	512 MSample	8 channels	20 MS/s	4 channels	20 MS/s	
M2p.5930-x4	16 Bit	512 MSample	1 channel	40 MS/s	1 channel	40 MS/s	OEM only
M2p.5931-x4	16 Bit	512 MSample	2 channels	40 MS/s	2 channels	40 MS/s	
M2p.5932-x4	16 Bit	512 MSample	4 channels	40 MS/s	2 channels	40 MS/s	
M2p.5936-x4	16 Bit	512 MSample	4 channels	40 MS/s	4 channels	40 MS/s	
M2p.5933-x4	16 Bit	512 MSample	8 channels	40 MS/s	4 channels	40 MS/s	
M2p.5940-x4	16 Bit	512 MSample	1 channel	80 MS/s	1 channel	80 MS/s	
M2p.5941-x4	16 Bit	512 MSample	2 channels	80 MS/s	2 channels	80 MS/s	
M2p.5942-x4	16 Bit	512 MSample	4 channels	80 MS/s	2 channels	80 MS/s	
M2p.5946-x4	16 Bit	512 MSample	4 channels	80 MS/s	4 channels	80 MS/s	
M2p.5943-x4	16 Bit	512 MSample	8 channels	80 MS/s	4 channels	80 MS/s	
M2p.5960-x4	16 Bit	512 MSample	1 channel	125 MS/s	1 channel	125 MS/s	
M2p.5961-x4	16 Bit	512 MSample	2 channels	125 MS/s	2 channels	125 MS/s	
M2p.5962-x4	16 Bit	512 MSample	2 channels	125 MS/s	2 channels	125 MS/s	
			4 channels	80 MS/s			
			4 channels	125 MS/s	4 channels	125 MS/s	
M2p.5966-x4	16 Bit	512 MSample	4 channels	125 MS/s	4 channels	125 MS/s	
M2p.5968-x4	16 Bit	512 MSample	4 channels	125 MS/s	4 channels	125 MS/s	
			8 channels	80 MS/s			

Options

Order no.	Option
M2p.xxxx-SH16ex ⁽¹⁾	Synchronization Star-Hub for up to 16 cards (extension), only one slot width, extension of the card to PCI Express 3/4 length (241 mm). 16 synchronization cables included.
M2p.xxxx-SH16tm ⁽¹⁾	Synchronization Star-Hub for up to 16 cards (top mount), two slots width, top mounted on card. 16 synchronization cables included.
M2p-upgrade	Upgrade for M2p.xxxx: Later installation of option Star-Hub

Services

Order no.	
Recal	Recalibration at Spectrum incl. calibration protocol

Cables

for Connections	Length	Order no.				
		to BNC male	to BNC female	to SMA male	to SMA female	to SMB female
Analog/Clock-In/Trig-In	80 cm	Cab-3f-9m-80	Cab-3f-9f-80	Cab-3f-3mA-80	Cab-3f-3fA-80	Cab-3f-3f-80
Analog/Clock-In/Trig-In	200 cm	Cab-3f-9m-200	Cab-3f-9f-200	Cab-3f-3mA-200	Cab-3f-3fA-200	Cab-3f-3f-200
Probes (short)	5 cm		Cab-3f-9f-5			
Clk-Out/Trig-Out/Extra	80 cm	Cab-1m-9m-80	Cab-1m-9f-80	Cab-1m-3mA-80	Cab-1m-3fA-80	Cab-1m-3f-80
Clk-Out/Trig-Out/Extra	200 cm	Cab-1m-9m-200	Cab-1m-9f-200	Cab-1m-3mA-200	Cab-1m-3fA-200	Cab-1m-3f-200

Amplifiers

Order no.	Bandwidth	Connection	Input Impedance	Coupling	Amplification
SPA.1412 ⁽²⁾	200 MHz	BNC	1 MOhm	AC/DC	x10/x100 (20/40 dB)
SPA.1411 ⁽²⁾	200 MHz	BNC	50 Ohm	AC/DC	x10/x100 (20/40 dB)
SPA.1232 ⁽²⁾	10 MHz	BNC	1 MOhm	AC/DC	x100/x1000 (40/60 dB)
SPA.1231 ⁽²⁾	10 MHz	BNC	50 Ohm	AC/DC	x100/x1000 (40/60 dB)
Information	External Amplifiers with one channel, BNC/SMA female connections on input and output, manually adjustable offset, manually switchable settings. An external power supply for 100 to 240 VAC is included. Please be sure to order an adapter cable matching the amplifier connector type and matching the connector type for your A/D card input.				

Software SBench6

Order no.	
SBench6	Base version included in delivery. Supports standard mode for one card.
SBench6-Pro	Professional version for one card: FIFO mode, export/import, calculation functions
SBench6-Multi	Option multiple cards: Needs SBench6-Pro. Handles multiple synchronized cards in one system.
Volume Licenses	Please ask Spectrum for details.

Software Options

Order no.	
SPc-RServer	Remote Server Software Package - LAN remote access for M2i/M3i/M4i/M4x/M2p cards
SPc-SCAPP	Spectrum's CUDA Access for Parallel Processing - SDK for direct data transfer between Spectrum card and CUDA GPU. Includes RDMA activation and examples. Signed NDA needed for access.

⁽¹⁾ : Just one of the options can be installed on a card at a time.

⁽²⁾ : Third party product with warranty differing from our export conditions. No volume rebate possible.

Technical changes and printing errors possible

SBench, digitizerNETBOX and generatorNETBOX are registered trademarks of Spectrum Instrumentation GmbH. Microsoft, Visual C++, Visual Basic, Windows, Windows 98, Windows NT, Window 2000, Windows XP, Windows Vista, Windows 7, Windows 8 and Windows 10 are trademarks/registered trademarks of Microsoft Corporation. LabVIEW, DASyLab, Diadem and LabWindows/CVI are trademarks/registered trademarks of National Instruments Corporation. MATLAB is a trademark/registered trademark of The Mathworks, Inc. Keysight VEE, VEE Pro and VEE OneLab are trademarks/registered trademarks of Keysight Technologies, Inc. FlexPro is a registered trademark of Weisang GmbH & Co. KG. PCIe, PCI Express and PCI-X and PCI-SIG are trademarks of PCI-SIG. LXI is a registered trademark of the LXI Consortium. PICMG and CompactPCI are trademarks of the PCI Industrial Computer Manufacturers Group. Oracle and Java are registered trademarks of Oracle and/or its affiliates. Intel and Intel Xeon are trademarks or registered trademarks of Intel Corporation. AMD and Opteron are trademarks or registered trademarks of Advanced Micro Devices.

