



## UC.6100 : 4 channel, 125 MS/s 8-bit Arbitrary Waveform Generators

- CompactPCI 6U format
- Fast 8 bit arbitrary waveform generators
- 2 or 4 channel versions
- Simultaneous sampling on all channels
- Output up to  $\pm 3$  V in 50 Ohm
- Amplifier option available for  $\pm 10$  V
- Offset and amplitude programmable
- 3 software selectable filters
- Up to 512 MSample memory
- FIFO mode
- Multiple card synchronization option
- Software SPEasyGenerator included



### Product range overview

Model	1 channel	2 channels	4 channels
UC.6110	125 MS/s	125 MS/s	
UC.6111	125 MS/s	125 MS/s	125 MS/s

### Software/Drivers

A large number of drivers and examples are delivered with the board or are available as an option:

- Windows 98/ME/NT/2000/XP - drivers
- Linux - drivers
- SBench 5.2
- Microsoft Visual C++ examples
- Borland Delphi examples
- Microsoft Visual Basic examples
- Microsoft Excel examples
- LabWindows/CVI examples
- FlexPro support with SBench
- LabVIEW - drivers (as option)
- DASYLab - drivers (as option)
- MATLAB - drivers (as option)
- Agilent VEE - drivers (as option)

### General Information

There are two UC.6100 AWG cPCI cards with 125 MS/s maximum output rates and either 2 or 4 channels. With these boards it is possible to generate freely definable waveforms on multiple channels synchronously.

Each channel has its own 8-bit D/A and three software selectable reconstruction filters. The internal standard Sync-bus allows multiple cards to be configured for higher channel counts. It is also possible to combine the arbitrary waveform generator with other boards of the UC product family like analogue or digital I/O boards.

With the up to 512 MSample on-board memory long waveforms can be generated even with high sampling rates. The memory can be used also as a FIFO buffer to make continuous data transfer from PC memory or hard disk.

### Hardware block diagram

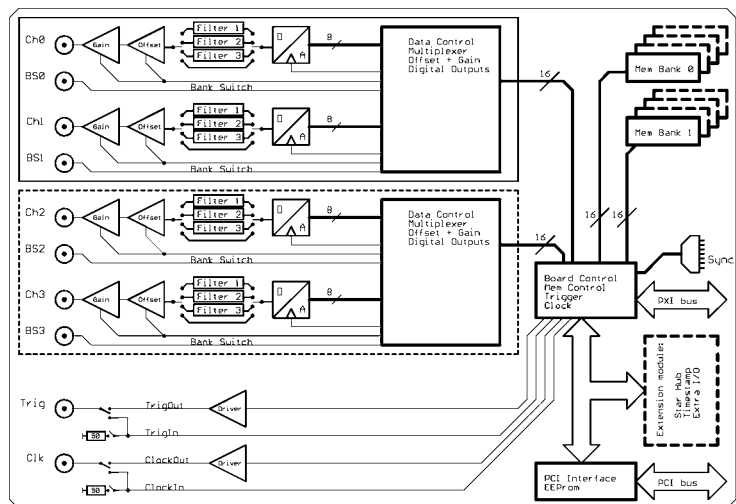

### Software programmable parameters

Sampling rate	1 kS/s to max sampling rate, external clock, ref clock
Output amplitude	$\pm 100$ mV up to $\pm 3$ V in 1 mV steps (Amp option: $\pm 333$ mV up to $\pm 10$ V)
Output offset	$\pm 3$ V selectable in 1 mV steps (Amp option: $\pm 10$ V in 3 mV steps)
Filters	no filter or one of 3 different filters as defined in technical data section
Mode	Singleshot, Continuous, Standard, Bank Switching
Clock mode	internal PLL, int.quartz, external, ext. divided, ext. reference clock
Clock impedance	50 Ohm / 1 MOhm
Trigger impedance	50 Ohm / 1 MOhm
Trigger mode	External, Software
Memory depth	32 up to installed memory in steps of 32
Posttrigger	32 up to 128 M in steps of 32
Multiple Replay segmentsize	32 up to installed memory / 2 in steps of 32

## Possibilities and options

### FIFO mode

The FIFO mode is designed for continuous data transfer between measurement board and PC memory (up to 100 MB /s) or hard disk (up to 50 MB/s). The control of the data stream is done automatically by the driver on interrupt request.

### External trigger I/O

All boards can be triggered using an external TTL signal. It's possible to use positive or negative edge also in combination with a programmable pulse width. A software trigger event can, when activated by software, be routed to the trigger connector to start external instruments.

### External clock I/O

Using a dedicated connector a sampling clock can be fed in from an external system. It's also possible to output the internal sampling clock to synchronise external equipment to this clock.

### Reference clock

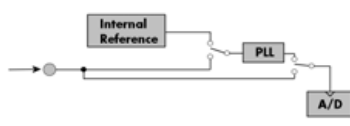

The option to use a precise external reference clock (normally 10 MHz) is necessary to synchronise the board for high-quality measurements with external equipment (like a signal source). It's also possible to enhance the quality of the sampling clock in this way.

The driver automatically generates the requested sampling clock from the fed in reference clock.

### Cascading

The Cascading option synchronises up to 4 Strategic Test boards internally. It's the easiest way to build up a multi channel system. There is a phase delay between two boards of about 500 pico seconds when this synchronisation option is used.

### Star Hub

The Star Hub is an additional module allowing the phase stable synchronisation of up to 16 boards. Independent of the number of boards there is no phase delay between all channels. The Star Hub distributes trigger and clock information between all boards. As a result all connected boards are running with the same clock and the same trigger.

### Extra I/O

The Extra I/O module adds 24 additional digital I/O lines and 4 analog outputs on an extra connector. These additional lines are independent from the standard function and can be controlled asynchronously. There is also an internal version available with 16 digital I/Os and 4 analog outputs that can be used directly at the rear board connector.

### Multiple Replay

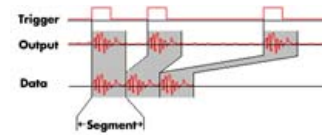

The Multiple Replay option allows the fast repetition output on several trigger events without restarting the hardware. With this option very fast repetition rates can be achieved. The on-board memory is divided in several segments of same size. Each of them is generated if a trigger event occurs.

### Gated Replay

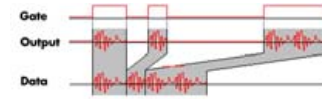

The Gated Replay option allows signal generation controlled by an external gate signal. Data is only output if the gate signal has a programmed level.

### Singleshot output

When singleshot output is activated the data in the on-board memory is output exactly one time. Either the external TTL trigger or the software trigger can be used.

### Continuous output

When continuous output is activated the data of the on-board memory is replayed continuously until a stop command is executed. As trigger source one can use the external TTL trigger or the software trigger.

### ±10 V Amplifier



The amplifier board allows the output of  $\pm 10$  V on up to four channels without software modification. The standard outputs of the card are amplified by factor 3.33. The amplifier has a 30 MHz bandwidth and an output impedance of 50 Ohm. This allows  $\pm 10$  V with high impedance termination or  $\pm 5$  V with 50 Ohm termination.

## Technical Data

Resolution	8 Bit	Dimension	160 mm x 233 mm (Standard 6U)
Integral linearity (DAC)	± 1.5 LSB typ.	Width (Standard)	1 slot (6U)
Differential linearity (DAC)	± 1.0 LSB typ.	Width (with star hub option)	2 slots (6U)
Output resistance	< 1 Ohm	Width Amplifier option	1 slot (3U)
Max output swing in 50 Ohm	± 3 V (offset + amplitude)	Analogue connector	3 mm SMB male
Max slew rate (no filter)	> 0.9 V/ns	Warm up time	10 minutes
Multi: Trigger to 1st sample delay	fixed	Operating temperature	0°C - 50°C
Multi: Recovery time	< 20 samples	Storage temperature	-10°C - 70°C
Ext. clock: delay to internal clock	42 ns ± 2 ns	Humidity	10% to 90%
Output to trigger out delay 1 channel	<10 MS/s: -10 sampl., >10 MS/s: -42 sampl.	Offset stepsize	< 2 mV
Output to trigger out delay 2 channels	<5 MS/s: -5 sampl., > 5 MS/s: -21 sampl.	Amplitude stepsize	< 1 mV
Crosstalk @ 1 MHz signal ±3 V	< -80 dB	Output accuracy	< 1%
Min internal clock	1 kS/s	Power consumption 3.3 V @ full speed	max. 1.51 A (5.0Watt)
Min external clock	DC	Power consumption 5 V @ full speed	max. 1.53 A (7.7 Watt)
Trigger input: Standard TTL level	Low: -0.5 V > level < 0.8 V High: 2.0 V > level < 5.5 V Trigger pulse must be valid ≥ 2 clock periods.	Clock input: Standard TTL level	Low: -0.5 V > level < 0.8 V High: 2.0 V > level < 5.5 V Rising edge. Duty cycle: 50% ± 5%
Trigger output	Standard TTL, capable of driving 50 Ohm. Low < 0.4 V (@ 20 mA, max 64 mA) High > 2.4 V (@ -20 mA, max -48 mA) One positive edge after the first internal trigger	Clock output	Standard TTL, capable of driving 50 Ohm Low < 0.4 V (@ 20 mA, max 64 mA) High > 2.4 V (@ -20 mA, max -48 mA)

## Clock and Filter

	UC.6110	UC.6111
max internal clock	125 MS/s	125 MS/s
max external clock	125 MS/s	125 MS/s
-3 dB bandwidth no filter	> 60 MHz	> 60 MHz
Filter 3: Characteristics	5th order Butterworth	5th order Butterworth
Filter 3: -3 dB bandwidth	25 MHz	25 MHz
Filter 2: Characteristics	4th order Butterworth	4th order Butterworth
Filter 2: -3 dB bandwidth	5 MHz	5 MHz
Filter 1: Characteristics	4th order Butterworth	4th order Butterworth
Filter 1: -3 dB bandwidth	500 kHz	500 kHz

## Dynamic Parameters

	UC.6110	UC.6110
	UC.6111	UC.6111
Test - Sample rate	125 MS/s	125 MS/s
Output Frequency	400 kHz	4 MHz
Output Level	±2 V	±2 V
Used Filter	500 kHz	5 MHz
SNR (typ)	> 60.5 dB	> 54.8 dB
THD (typ)	< -68.8 dB	< -57.8 dB
SFDR (typ), excl harm.	> 71.5 dB	> 65.2 dB

Dynamic parameters are measured at the given output level and 50 Ohm termination with a high resolution data acquisition card and are calculated from the spectrum. The sample rate that is selected is the maximum possible one. All available channels are activated for the tests. SNR and SFDR figures may differ depending on the quality of the used PC. SNR = Signal to Noise Ratio, THD = Total Harmonic Distortion, SFDR = Spurious Free Dynamic Range

## Order information

Order No	Description	Order No	Description
UC6110	UC.6110 with 16 MSample memory and drivers/SBench 5.x	UC6100-32M	Option: 32 MSample mem instead of 16 MSample standard mem
UC6111	UC.6110 with 16 MSample memory and drivers/SBench 5.x	UC6100-64M	Option: 64 MSample mem instead of 16 MSample standard mem
UC6000-smod	Star Hub: Synchronisation of 2 - 16 boards, one option per system	UC6100-128M	Option: 128 MSample mem instead of 16 MSample standard mem
UC6100-xmf	Extra I/O, external connector: 24 DI/O, 4 Analog out, incl. cable	UC6100-256M	Option: 256 MSample mem instead of 16 MSample standard mem
UC6100-dl	DASYLab driver for UC.6100 series	UC6100-512M	Option: 512 MSample mem instead of 16 MSample standard mem
UC6100-hp	VEE driver for UC.6100 series	UC6100-up	Additional handling costs for later memory upgrade
UC6100-lv	LabVIEW driver for UC.6100 series	UC6000-mr	Option Multiple Replay: Memory segmentation
UF/UC/UX-ml	MATLAB driver for all UF/UC/UX series.	UC6000-gs	Option Gated Sampling: Gate signal controls replay
Cab-3f-9m-80	Adapter cable: SMB female to BNC male 80 cm	UC6000-cs	Synchronisation of 2 - 4 boards, one option per system
Cab-3f-9m-200	Adapter cable: SMB female to BNC male 200 cm	MC6000-1Amp	±10 V Amplifier board with 1 channel
Cab-3f-9f-80	Adapter cable: SMB female to BNC female 80 cm	MC6000-2Amp	±10 V Amplifier board with 2 channels
Cab-3f-9f-200	Adapter cable: SMB female to BNC female 200 cm	MC6000-4Amp	±10 V Amplifier board with 4 channels

technical changes and printing errors possible

